

PUFFERSPHEREXL

by pufferfish ltd



Fits Industry standard Barco 10k
CLM R10 Projector

Lightweight Aluminium frame,
available in black or custom

Pufferfish automated stealth
inflation system: near-silent

Trademark Pufferfish flexibility;
use floor-standing, wall-mounted
horizontally or flown

Rapid set-up and strike:
simple to use, solid, sturdy and safe

Single lens system:
no time consuming edge-blending

Available with 1.6 – 2.5m diameter
interchangeable inflatable projection spheres

Lovingly designed by Pufferfish for Coldplay's Viva la Vida World Tour

Email: info@pufferfishdisplays.co.uk

252 Causewayside, Edinburgh, EH9 1UU, UK

T: +44 (0)131 668 3360 F: +44 (0)131 667 5864



www.pufferfishdisplays.co.uk

puffersphere

XL

Xtra Large

Xtra Light

Xtra Love

Designed for advertising, dressing / branding, digital signage, data visualisation and special effects.

Suitable for permanent and temporary installation in stage shows, TV and film studios, trade shows, entertainment venues, hospitality suites, nightclubs, museums, expos and places of worship.

Rig/run straight from flight case: set up from 30 minutes.

Projector can be integrated into the PufferSphere XL unit or used stand-alone with a standard throw lens.

Combine with a Green Hippo Hippotizer to spherize content in real-time and sync with other media.

Pre render content in Adobe After Effects.

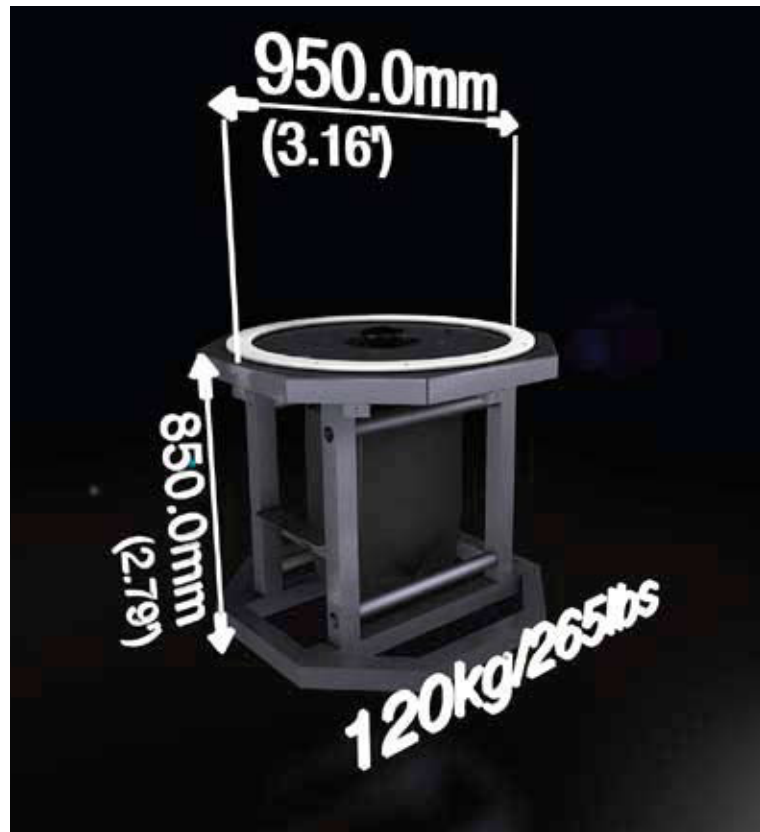
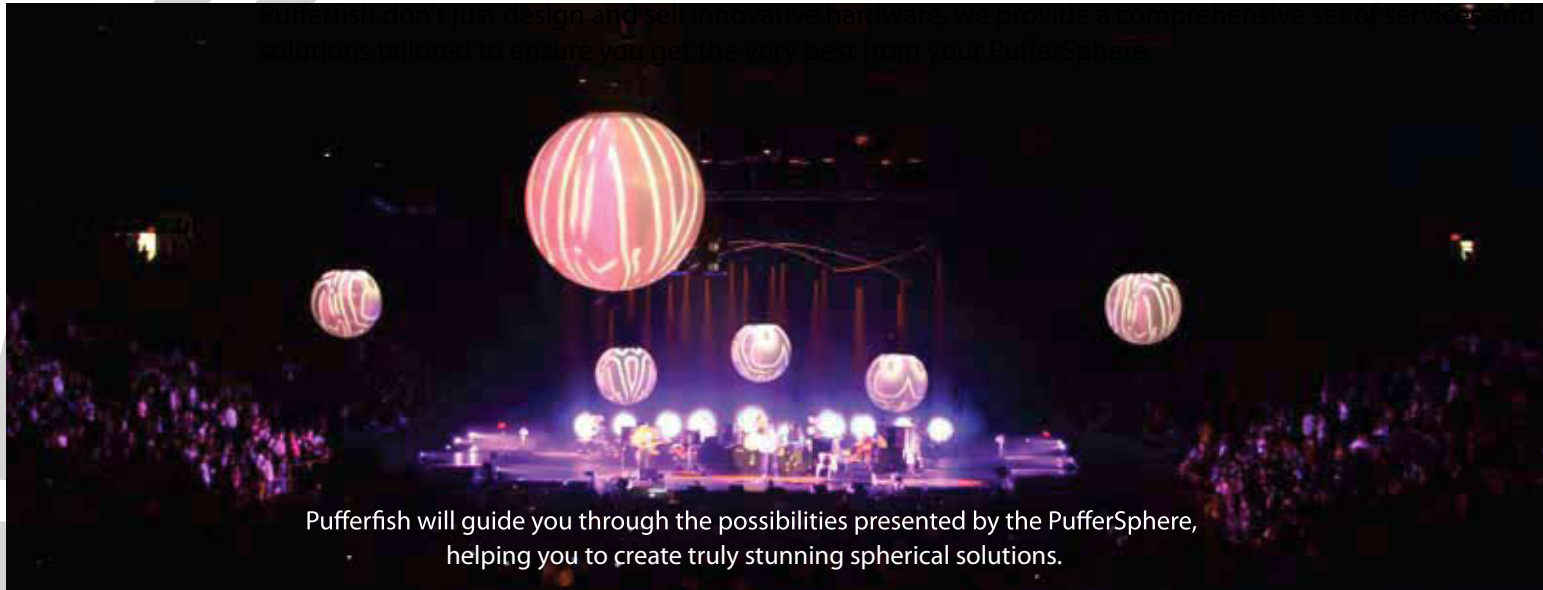

Pufferfish and PufferSphere are registered Trade Marks of Pufferfish Ltd
 Registration Nos. 2445143 and 2445137
 International (PCT) Patent Application No. PCT/GB2007/004564
 Copyright Pufferfish 2009. Design Rights Pufferfish 2009



www.pufferfishdisplays.co.uk